

Part 3

Assembling the Rear threaded rods

In this section you will construct the set of rear threaded rods that interconnects the pair of apex triangle sections and carries the Y axis idler.

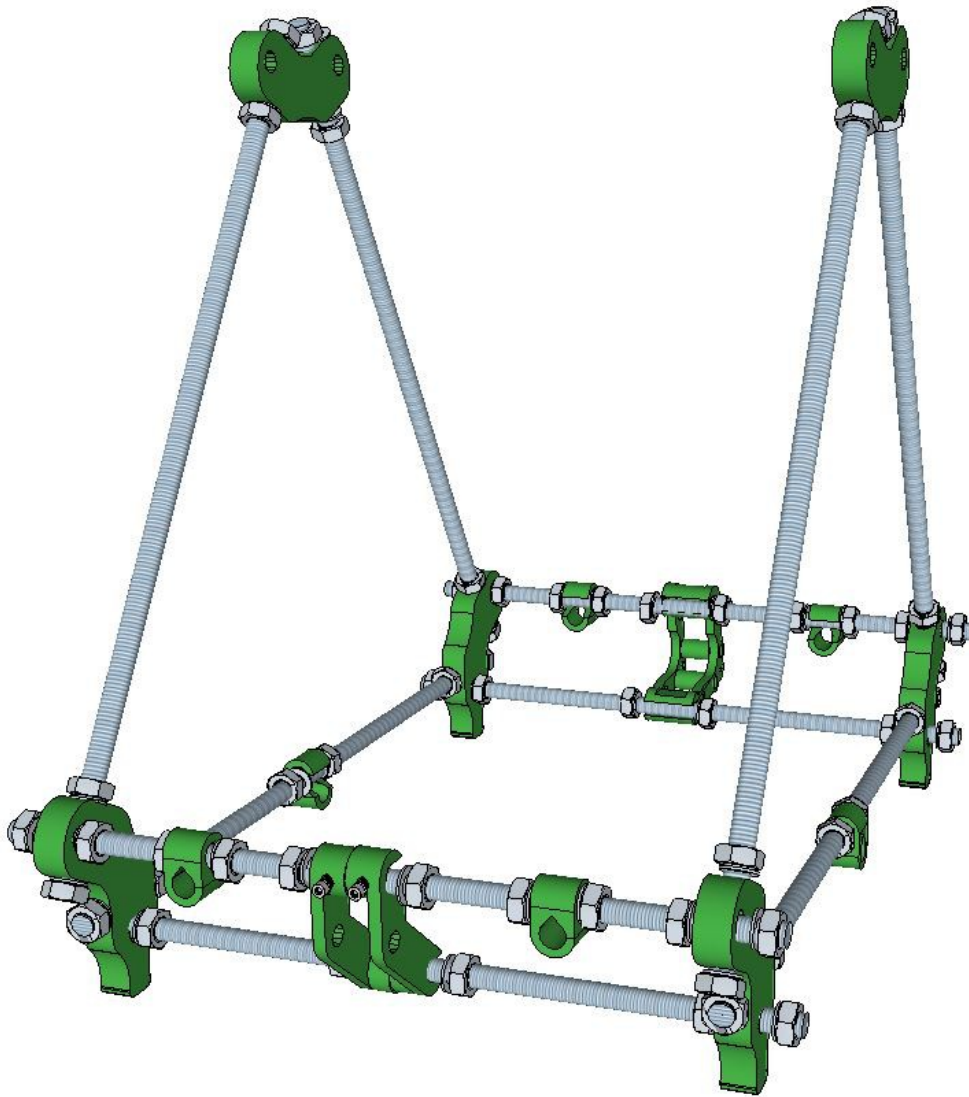

Parts

You will need the following parts;

- 2 x printed Y idler bracket pieces
- 2 x printed bar clamps
- 2 x 310mm threaded rod
- 16 x M8 nuts
- 16 x M8 washers

Preparation

Make sure the threaded rods are de-burred by screwing a bolt on to each end. If the fit is a problem work a nut down to and off the troublesome end to ease the burr.

The four holes in each apex piece for M8 threaded rods to pass through should have been eased in a previous section.

Particular care needs to be taken easing the bar clamps with a file, do not take off too much material and make sure an M8 threaded rod can fit in both the hook and the tear drop hole snugly.

The idler bracket needs to slide on to the M8 threaded rods so ease these slots enough to allow that. The remaining holes in the bracket should be eased to allow an M8 bolt to slide through cleanly, the easiest way to do this is with a small circular file or an M8 drill bit.

1

Thread the bottom 310mm rod first. Thread an M8 nut onto the middle of the rod. Slide an M8 washer next to it.

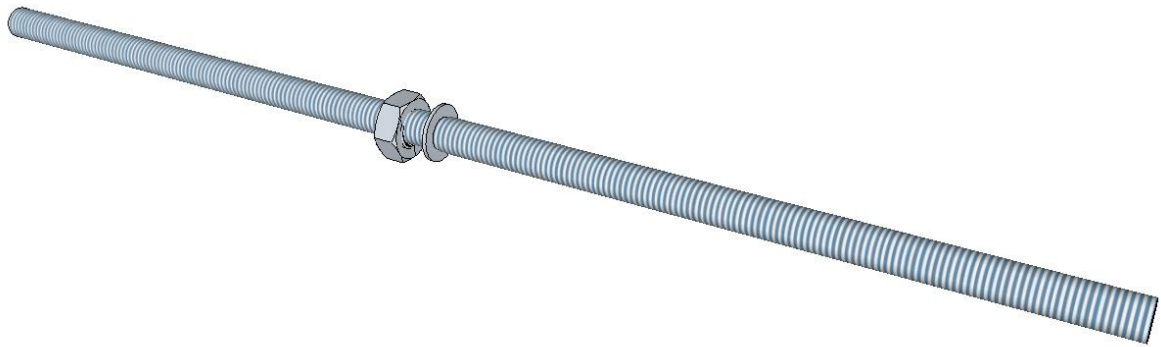

2

Mate the two halves of the Y idler bracket together as shown with two M3x20 cap screw and nuts then slot the rod into the bottom slot of the two arms of the bracket.

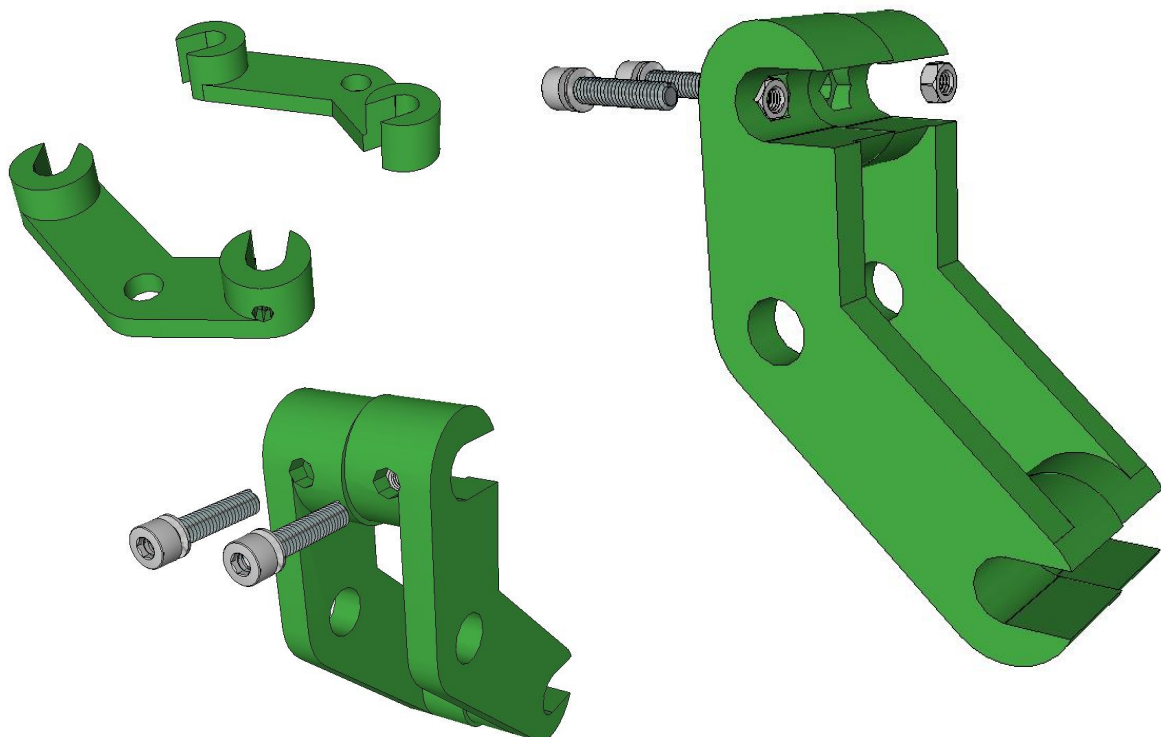

3

Slide another washer onto the other side of the rod and add another M8 nut to hold it in place.

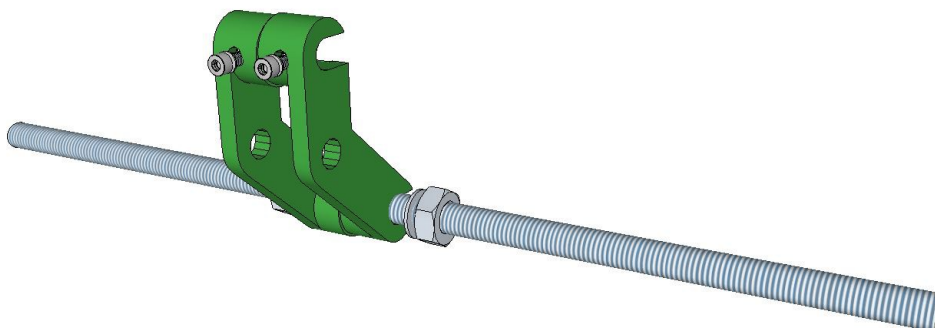

4

Add a nut and washer to each end of the rod.

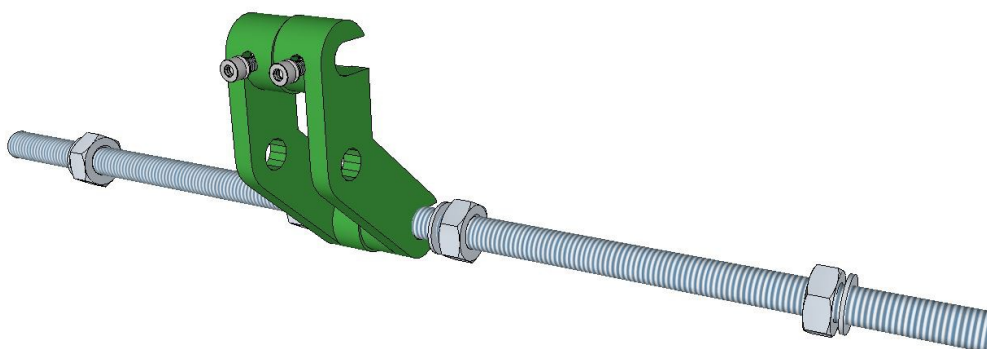

5

Now thread the top 310mm rod. This is a complicated one, so make sure you get it all done in the right order. From left to right, the rod should have: 1 washer, 2 nuts, 1 washer, 1 bar clamp (slipped on to the rod), 1 washer, 2 nuts, 1 washer, then the y-idler-bracket.

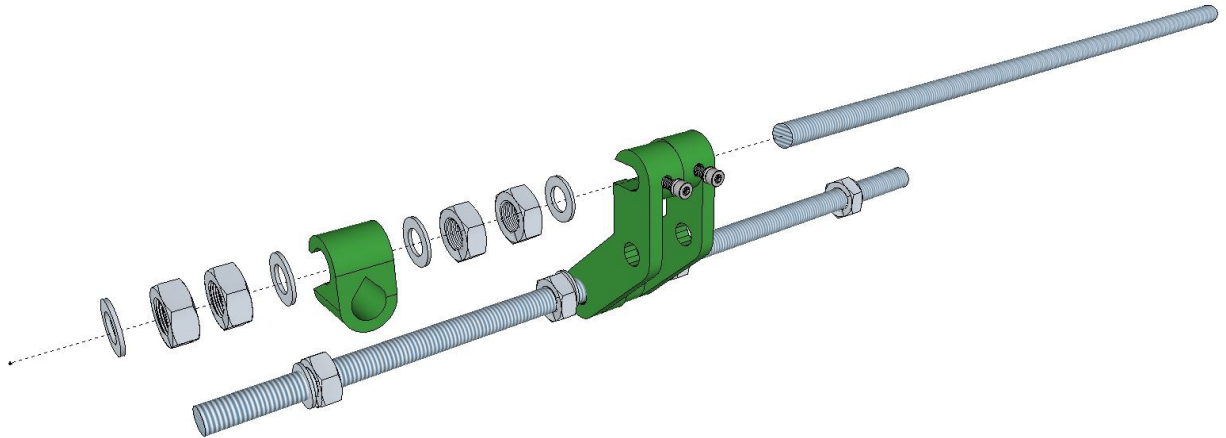

[Lefthand Side]

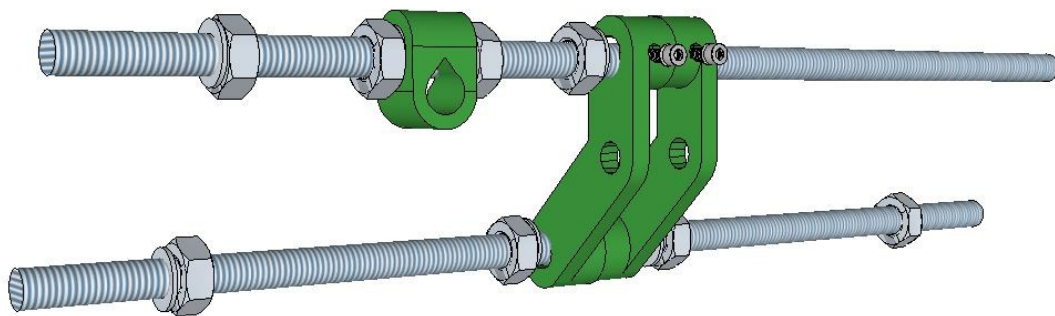

The right hand side is simply a repeat of the left. From left to right, the rod should have: 1 washer, 2 nuts, 1 washer, 1 bar clamp (slipped on to the rod), 1 washer, 2 nuts, and 1 washer.

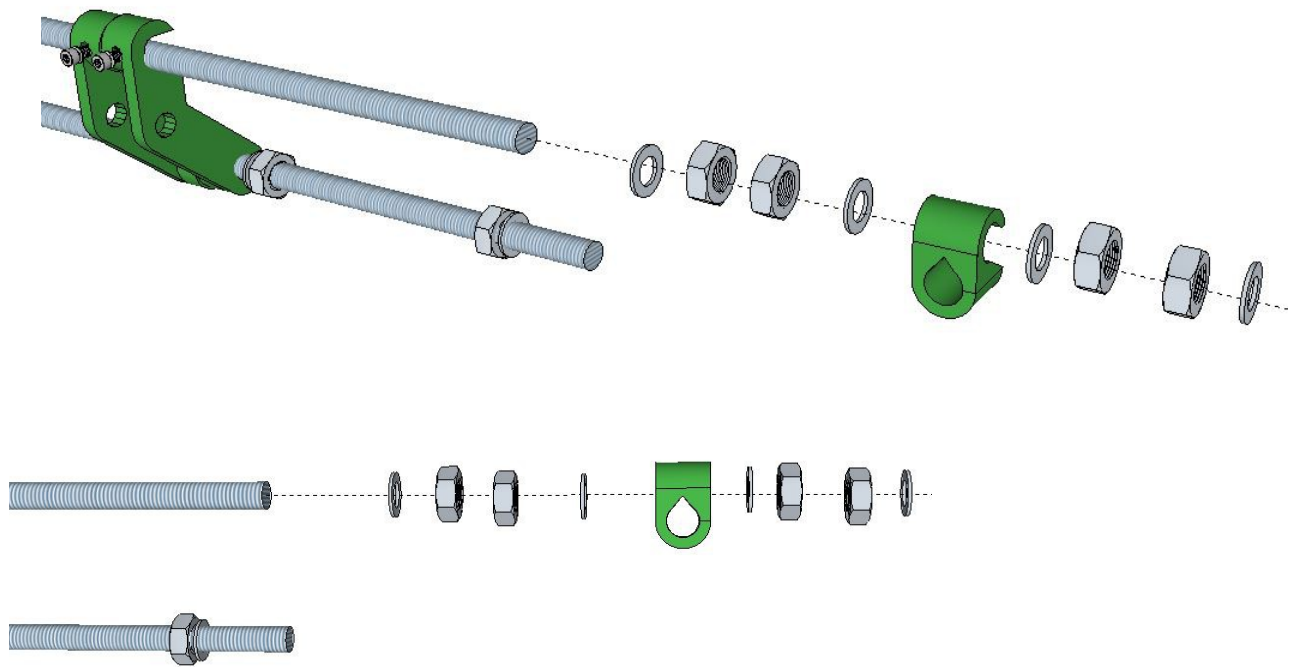

[Righthand Side]

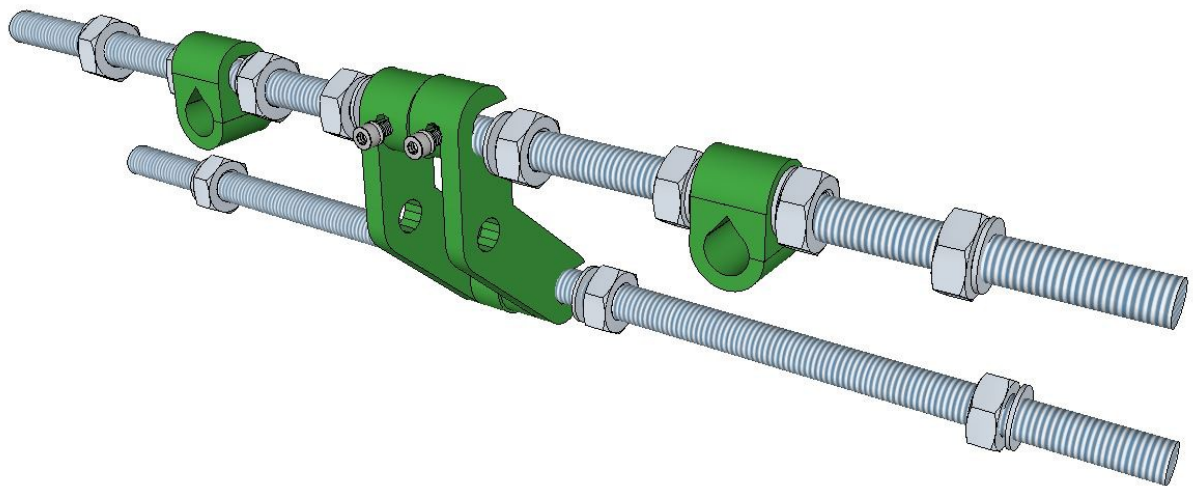

6

When you hold it with the bar clamps at the top it should look like the picture below with the elbow of the idler bracket sticking out towards you. Verify this now.

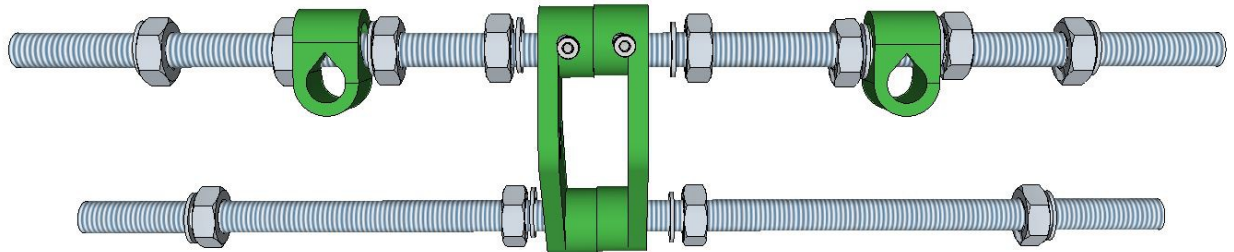

7

You can now attach this set up to the triangle sides. Make sure the bigger part of the idler bracket points OUT of the triangle. Thread the ends of the rods through two of the footed vertices. Put a washer and nut on the end of each threaded rod. It should now look like this:

